

BGL®

Tools for Bearings

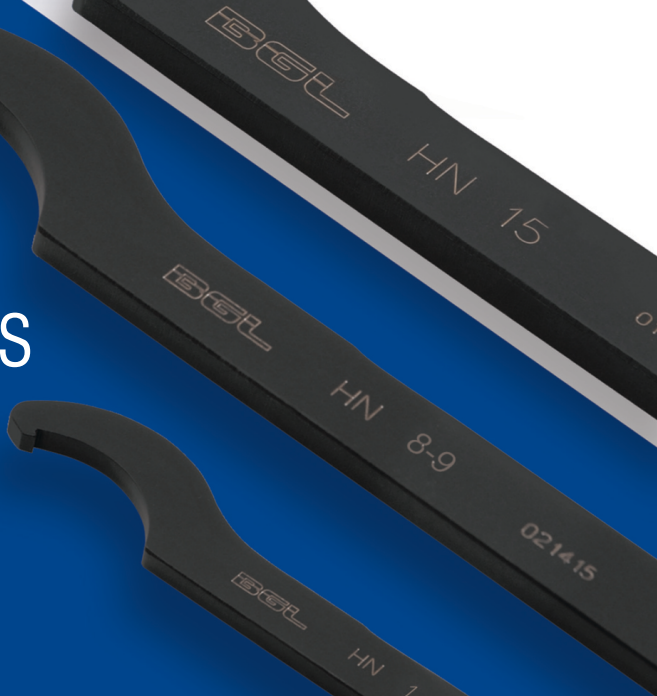

HOOK SPANNERS



HOOK SPANNERS TOOL

BGL[®]

BGL HOOK SPANNERS

Designed to facilitate the **assembly and disassembly of BGL KM Lock Nuts**, they are also compatible with Lock Nuts according to DIN 981 and DIN 1804 standards, including types N, AN, KMP, KMFE, KMT, and GUK.

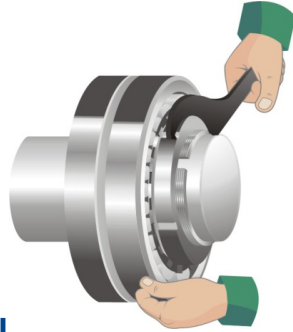

MATERIAL

SAE 1045 steel with heat treatment and black oxide finish.

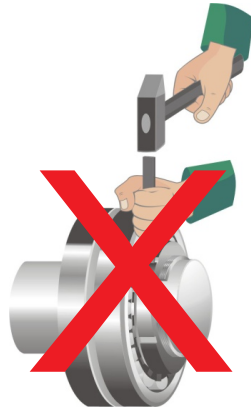

IMPORTANT

The use of non-recommended tools for this function reduces the lifespan of the bearings.



TO SELECT THE CORRECT HOOK SPANNER, USE THE TABLE BELOW

Contact us for special dimensions!

CODE	Dm Min. (mm)	Dm Max. (mm)	L mm	L1 mm	S (mm) Pol.
HN 1	20	22	100	108	3.2
HN 2-3	25	28	120	136	4.8
HN 4	30	32	120	136	4.8
HN 5-6	38	45	150	170	4.8
HN 7	52	55	180	205	6.4
HN 8-9	58	65	210	240	8.0
HN 10-11	68	75	210	240	8.0
HN 12-13	80	90	240	280	8.0
HN 14	92	92	240	280	8.0
HN 15	95	100	240	280	8.0
HN 16	105	105	240	280	8.0
HN 17	110	115	280	333	12.7
HN 18-20	120	130	280	330	12.7
HN 21-22	135	145	320	381	12.7
HN 23	150	150	340	405	12.7
HN 24	155	155	360	426	12.7
HN 25	160	160	380	445	12.7
HN 26	165	165	400	465	12.7
HN 27	175	175	420	495	15.9
HN 28	180	180	440	516	15.9
HN 29	190	190	460	542	15.9
HN 30	195	195	480	566	15.9
HN 31	200	200	500	585	15.9
HN 32-33	210	210	500	587	15.9
HN 34	220	220	510	603	15.9
HN 36	230	230	540	634	15.9
HN 38	240	240	555	653	15.9
HN 40	250	250	575	676	15.9
HN 44	280	280	600	715	15.9
HND 280-300	280	300	550	683	15.9
HND 300-320	300	320	550	695	15.9
HND 320-345	320	345	550	695	15.9
HND 350-375	350	375	585	740	15.9
HND 380-400	380	400	620	795	15.9
HND 410-430	410	430	670	845	19.0
HND 440-470	440	470	750	938	19.0
HND 480-500	480	500	800	1000	22.0
HND 520-540	520	540	840	1050	22.0

ATTENTION WHEN CHOOSING THE SPANNER!

Some Lock Nuts may have an external diameter outside the standard coverage range of Hook Spanners. In such cases, it is recommended to use the next smaller size Spanner.

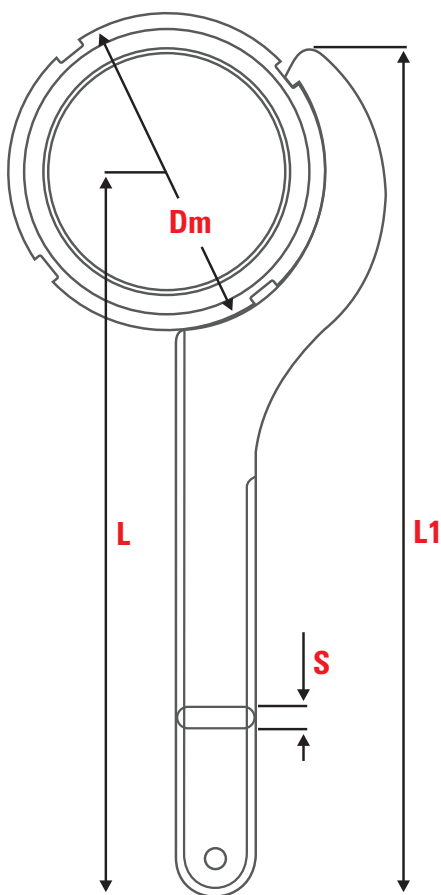

- Dm** External Diameter Nut
- L** Length to the Center Nut
- L1** Total Length Spanner
- S** Thickness

EXAMPLES FOR SPECIFYING THE SPANNER SIZE FOR KM LOCKNUTS

Bearing 1317 K

Sleeves H 317

Lock Nut KM 17

Hook Spanner HN 17

Bearing 1320 K

Sleeves H 320

Lock Nut KM 20

Hook Spanner HN 18-20

Determine the Spanner based on the **external diameter** of the **Lock Nut**.

For **other types of Lock Nuts**, refer to the **external diameter in the table**.

HOOK SPANNER SIZE COMPARISON



HN 2-3

HN 16

HND 280-300

HND 380-400

WITH BGL TOOLS, YOU ALWAYS WIN

With the BGL Hook Spanner, you ensure correct mounting of Sleeves and Lock Nuts, prolonging bearing life and reducing assembly/disassembly time more safely.

BGL ORIGINAL PARTS

All BGL parts and tools come laser-marked with the BGL logo, part code, and lot number. This ensures traceability, easy identification, and guarantees authenticity as original BGL parts.



HOOK SPANNER KIT

In addition to individual Spanners, BGL offers this kit below, with 9 different Hook Spanner sizes for practical and safe storage and transport.

Fits KM Lock Nuts, sizes 4 to 16.

Order using code: **HN 4-16 KIT**



TO LEARN MORE

Watch our **demo videos 1, 3, 6, 8, and 14** on how to use **Hook Spanners**:
www.bgl.com.br/treinamento.htm

CONTACT YOUR DISTRIBUTOR

2026/02 Release

BGL is a 100% Brazilian company and a market leader in industrial bearing accessories. With nearly 70 years of tradition, our core values are quality, agility, and ethics, which ensure a high standard of quality, credibility, and precision — attributes recognized worldwide.



INDUSTRIAL BEARING LINE

PRODUCTS

- Adapter Sleeves
- Hydraulic Adapter Sleeves
- Withdrawal Sleeves
- Hydraulic Withdrawal Sleeves
- Locking Nuts, Adjustment Nuts, Self-Locking Nuts
- Precision Nuts
- Lock Washers, Locking Devices

TOOLS

- Hydraulic Pumps
- Hydraulic Nuts
- Dial Indicator with Extensions Rods
- Hook Spanners
- Extension Tubes
- Feeler Gauges
- Training Kit

Contact us for Special Parts!

Quality • Accuracy • Agility • Tradition • Ethics

BGL[®]

Tools for Bearings

Since 1957 • ISO 9001

BGL - BERTOLOTO & GROTTA LTDA.

Av. Major José Levy Sobrinho, 1296
13486-190 • Limeira-SP • Brazil
+55 19 3451.8210 • +55 19 99155.1332
info@bgl.com.br • www.bgl.com.br/en

