

FACILITE SEU TRABALHO COM AS SOLUÇÕES HIDRÁULICAS BGL

Com a Bomba Hidráulica, Tubos de Extensão, Buchas e Porcas Hidráulicas, é possível montar e desmontar conjuntos de grande porte em poucos minutos, possibilitando uma operação leve, segura e redução no tempo de máquinas paradas.



Accessórios para Rolamentos

Acesse www.bgl.com.br/treinamento.htm e conheça mais sobre as vantagens de redução de tempo de manutenção, usando as Soluções Hidráulicas.

FACILITE SU TRABAJO CON LAS SOLUCIONES HIDRÁULICAS BGL

Con la Bomba Hidráulica, Tubos de Extensión, Manguitos y Tuercas Hidráulicas es posible montar y desmontar grupos de piezas en pocos minutos, lo que permite una operación ligera y segura, así como una reducción del tiempo de inactividad de máquina.



Accesorios para Rodamientos

Acceder www.bgl.com.br/esp/treinamento.htm y saber más sobre las ventajas de la reducción del tiempo de mantenimiento de equipo usando las Soluciones Hidráulicas.

MAKE YOUR WORK EASIER WITH BGL HYDRAULIC SOLUTIONS

With Hydraulic Pump, Extension Tubes, Hydraulic Sleeves and Nuts, it is possible to mount and dismount large sets (bearings and sleeves) in just a few minutes, enabling a light and safe operation as well as reduction of machines downtime.



Bearing Accessories

Access www.bgl.com.br/en/treinamento.htm and learn more about the advantages of using Hydraulic Solution to reduce maintenance time.



www.bgl.com.br



APP BGL  

Versão 09/2025



www.bgl.com.br/esp



APP BGL  

Versión 09/2025



www.bgl.com.br/en



APP BGL  

2025/09 Release

COM O MÍNIMO DE ESFORÇO E MÁXIMA EFICIÊNCIA



BUCHAS HIDRÁULICAS OH, OHE, OHA, OHS, OSNW, OSNP

São providas com canaletas para injeção e distribuição de óleo. São recomendadas para eixos a partir de 140 mm para facilitar a desmontagem.



PORCAS HIDRÁULICAS HMV_E, HMVC_E, HMV_E/A, HMVF

Facilita a montagem e desmontagem de rolamentos em buchas cônicas ou eixos.

CON UN MÍNIMO ESFUERZO Y LA MÁXIMA EFICIENCIA



MANGUITOS HIDRÁULICOS OH, OHE, OHA, OHS, OSNW, OSNP

Estos componentes tienen canales para inyección y distribución de aceite. Son recomendados para ejes de tamaño gran desde 140 mm para facilitar el proceso de desmontaje.



TUERCAS HIDRÁULICAS HMV_E, HMVC_E, HMV_E/A, HMVF

Estas hacen que sea más fácil el montaje y desmontaje de rodamientos de agujero cónico em los manguitos o ejes.

WITH MINIMAL EFFORT AND MAXIMUM EFFICIENCY



HYDRAULIC SLEEVES OH, OHE, OHA, OHS, OSNW, OSNP

They are provided with oil duct and grooves for oil injection and distribution. They are recommended for shafts from 140 mm diameter.



HYDRAULIC NUTS HMV_E, HMVC_E, HMV_E/A, HMVF

They make it a lot easier to mount and dismount tapered bore bearings onto sleeves or shafts.

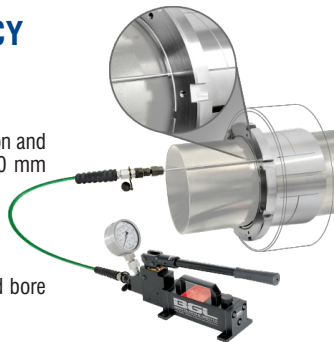
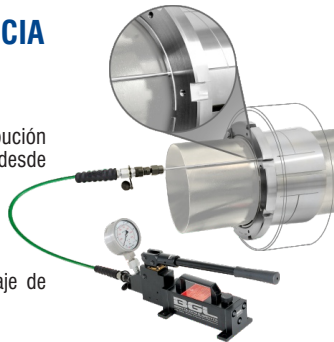
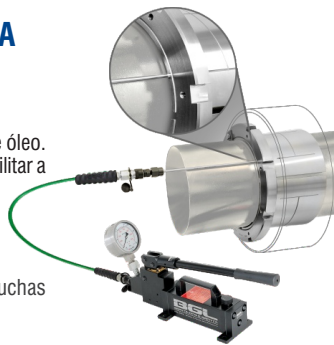

BGL



TUBOS DE EXTENSÃO | TE

Conexão fina para acesso às paredes estreitas da Bucha Hidráulica e conexão na mangueira da Bomba Hidráulica.

BOMBAS HIDRÁULICAS | BH

Para deslocar e movimentar corpos muito pesados com extrema facilidade.

BH 100-0.7 / BH 100-0.7 D | 100 MPa
BH 160 / BH 160D | 160 MPa
BH 160-4.8 / BH 160-4.8D | 160 MPa

BGL



TUBOS DE EXTENSIÓN | TE

Conexión fina para acceder a las paredes estrechas del manguito hidráulico y a la conexión de la manguera de la bomba hidráulica.

BOMBAS HIDRÁULICAS | BH

Para desplazar y mover cuerpos muy pesados con extrema facilidad.

BH 100-0.7 / BH 100-0.7 D | 100 MPa
BH 160 / BH 160D | 160 MPa
BH 160-4.8 / BH 160-4.8D | 160 MPa

BGL



EXTENSION TUBES | TE

Fine connection access between the narrow walls of the Hydraulic Sleeves and the Hydraulic Pump hose.

HYDRAULIC PUMPS | BH

They are used to shift and move very heavy bodies with extreme ease through oil injection.

BH 100-0.7 / BH 100-0.7 D | 100 MPa
BH 160 / BH 160D | 160 MPa
BH 160-4.8 / BH 160-4.8D | 160 MPa